

TAPMAN®

**DUAL OUTPUT
PID CONTROLLER**

**OPERATING INSTRUCTIONS
Model: PID2**

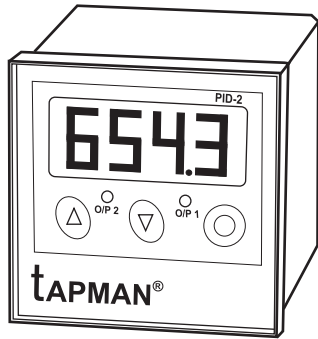

Congratulations

on selecting this state of the art microcontroller based instrument.

Please read the following before use

WARNING Serious injury may result if instructions are not followed.

- ⚠ This unit is not designed as a safety device.
- ⚠ Failure of devices, such as the thermocouple/ RTD sensor, heater, output Relay, SSR or temperature controller itself can result in severe damage to a product while in process, melting of the heater or a damaging fire.
- ⚠ An over-temperature protection device must be installed in your process that will remove all power from the heating circuit if the above failure occurs.
- ⚠ Failure to install temperature limiting control protection where a potential hazard exists could result in damage to equipment and property and fatal injury to personal.

CAUTION Product may be damaged or injury may result if instructions are not followed.

- > This unit should be installed in a panel.
- > Do not use the instrument outdoors.
- > The protection device of this unit may be damaged if instructions are not followed.
- > Do not use the instrument in places where there is excessive of dust, corrosive gases, oil spilling, high humidity, condensation, direct sunshine, radiant heat, vibration, shock occur.
- > Unused terminals should not be used as jumper. As they may be connected internally.
- > Clean the unit with dry cloth only after turning the power off.
- > Do not modify or disassemble the unit.
- > Power switch or a circuit breaker should be installed near the unit in order to cut the power supply.
- > Do not connect power to sensor terminals.

Set Value Adjustment

Set value 1 can be adjusted as follows.

- ⚙ Press the **⏻** button. The display shows **[5E1]**. Leave the **⏻** button.
- ⚙ Now the display show Set value 1. Display will be flashing.
- ⚙ To change, use either **⏴** or **⏵** button to increase or decrease the value respectively.
- ⚙ Keeping either **⏴** or **⏵** button pressed for more than 2 seconds will result in a rapid change of the value.
- ⚙ To save this new value, press the **⏻** button while the display is still flashing.

Set value 2 (or Alarm) can be adjusted as follows.

- ⚙ Keep the **⏻** button pressed (for about 7 seconds). The display will show **[ALr]** (or one of the following **[ALr]**, **[hALr]**, **[hALu]**, **[52h]**, **[52c]** depending on selected functionality of 2nd o/p).

- ⚙ Leave the **⏻** button.
- ⚙ Now the display show Set 2 (or Alarm) value. Display will be flashing.
- ⚙ To change, use either **⏴** or **⏵** button to increase or decrease the value respectively.
- ⚙ Keeping either **⏴** or **⏵** button pressed for more than 2 seconds will result in a rapid change in the value.
- ⚙ To save this new value, press the **⏻** button while the display is still flashing.

Configuration

Before the controller can be used, it has to be configured properly. This can be done as follows:

- ✓ Remove power to the controller.
- ✓ Keep the **⏻** button pressed and then apply power.
- ✓ When the display shows **[Conf]** release the **⏻** button.
- ✓ On releasing the **⏻** button the display shows **[ESC]**.

- ✓ Press the **⏻** button briefly the display shows **[5En]**. Now press the **⏻** button. The display now shows the selected sensor.
- ✓ Press **⏴** or **⏵** button to change the sensor.
- ✓ After the desired sensor is displayed, press the **⏻** button again. The display now shows **[5En]** again.
- ✓ Using **⏴** or **⏵** buttons navigate through the other configuration parameters.
- ✓ To change the value of any configuration parameter press **⏻** button and then using **⏴** or **⏵** change to the desired value.
- ✓ After all the changes have been done use or button to comeback to **[ESC]**. To save the changes made, press the **⏻** button when the display is still showing **[ESC]**.

Config Parameters

† is the factory default value.

[5En] Sensor Selection

[Pt1]	Pt100 _{DIN}
† [J]	J type
[K]	K type
[hPt1]	Pt100 _{DIN} Res: 0.1°C 4 digit display model only

[Con] Control

† [PID]	PID Control
[HEAT]	Heating control
[COOL]	Cooling control

[hYS1] Hysteresis Value

Hysteresis value in °C effective only when the controller is running in HEAT or COOL Mode.

Range: 0.2 - 99.9 °C † : 2.0 °C

[GA in] PID Gain

This is the PID Gain.	† : 6.0
Range: 1.0 - 99.9	3 Digit model
1.0 - 199.9	4 Digit Model

[in-t] Integral Time

This is the Integral time.	† : 250
Range: 10 - 999	3 Digit model
10 - 5000	4 Digit Model

[dF-t] Derivative Time

This is the Derivative time.	† : 70
Range: 0 - 500	

[tunE] Auto tuning lock

† [oPEN]	No Lock, Auto tuning can be done.
[onCE]	Auto tuning can be done once only. After Successful completion of auto tuning this parameter will be changed to [LoC]
[LoC]	Auto tuning not allowed.

[CYC] Cycle time

Significant only when [PID] mode is selected in [Con]
Range: 1 to 250 Seconds. † : 6

[oP2] Output 2 type

† [ALr]	Overshoot alarm Res:1°C
[ALu]	Undershoot alarm Res:1°C
[hALr]	Overshoot alarm Res:0.1°C
[hALu]	Undershoot alarm Res:0.1°C
[52h]	Setpoint 2 HEAT type cont
[52c]	Setpoint 2 COOL type cont

hYS2 Hysteresis Value

Hysteresis value in °C effective for second output.

Range: 0.2 - 99.9 °C † : 2.0 °C

iPC Input correction

Zero adjustment of sensor input.

Range: -19.9 to 99.9 3 Digit model
-99.9 to 99.9 4 Digit Model

† : 0.0

hSP Setpoint Max Value

Adj within the sensor operation range.

Operator will not be able to set the set point more than this value. Can be used to set the upper limit of Set point.

ESC Escape / Exit

Pressing the Ⓞ button at this parameter will save the changes and make the controller come out of config mode.

Sensor Ranges

Sensor	3 Digit Model		4 Digit Model	
	Min	Max	Min	Max
Pt100 _{DIN}	-99°C	660°C	-160°C	660°C
J	-99°C	870°C	-200°C	870°C
K	-99°C	999°C	-190°C	1300°C
Pt100 _{DIN}	N.A	N.A	-160.0°C	660.0°C

ERROR Diagnosis

The instrument display flashes **Err1** if

Condition 1: Sensor selected is Thermocouple:

Cause: Sensor is open or internal cold junction compensation circuit is damaged.

Short Terminals 1 and 2 together and then check again.

→ If the display still flashes then the problem is internal to the unit. In this case send back the unit to the factory for service.

→ If the display starts showing the room temperature, then check the wiring connection to the thermocouple.

Condition 2: Sensor selected is RTD:

Cause: Sensor is open or short circuited.

→ Connect a known good sensor to the unit and then check again.

→ If the display no longer flashes then check the wiring connection to the RTD

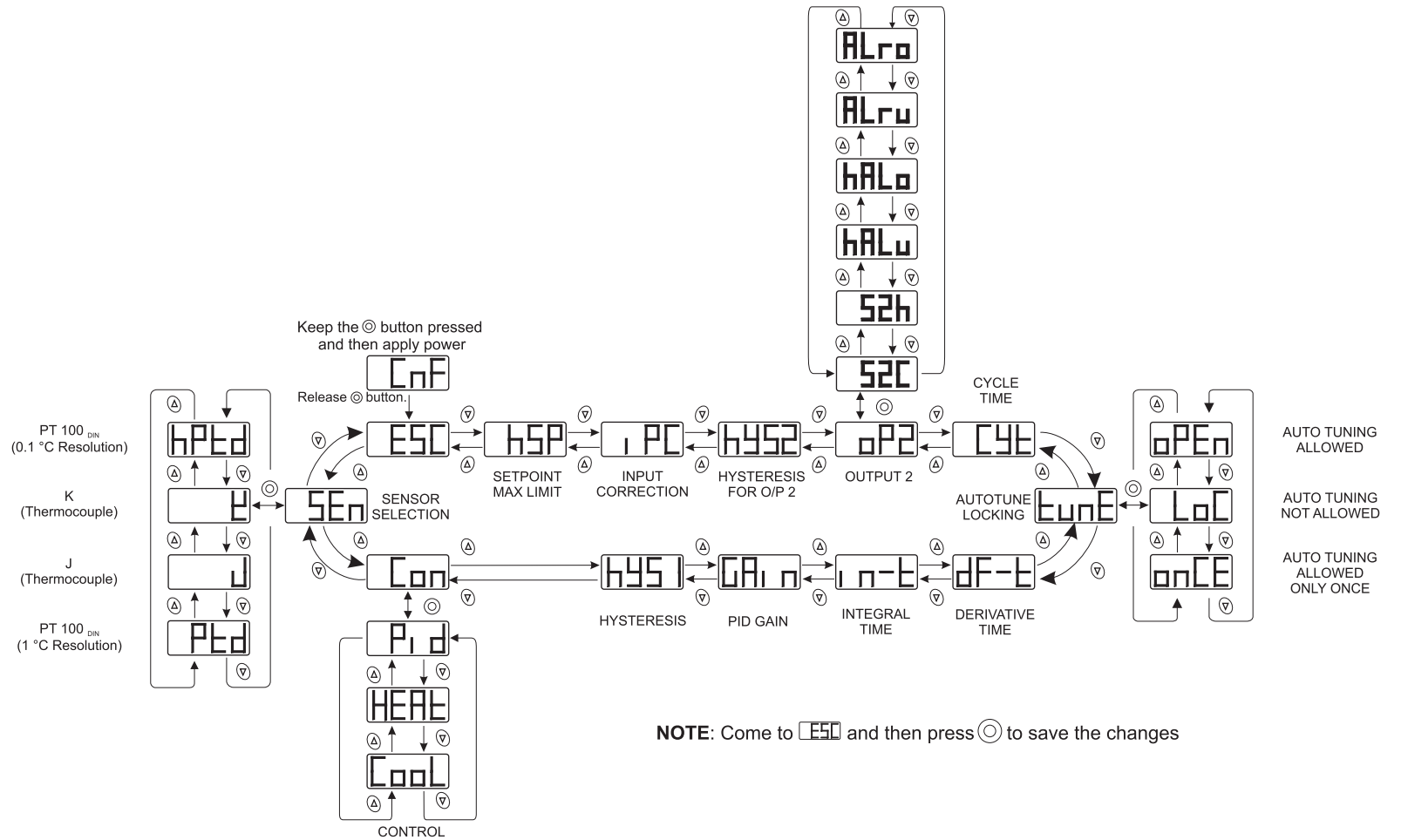

Navigation Chart